



# Kindergarten Packet

Consonant Z

Name: \_\_\_\_\_

\_\_\_\_\_

\_\_\_\_\_

Welcome to the *Reading Horizons Discovery*<sup>®</sup> Kindergarten Weekly Student Packet! In this packet, you'll find activities that students can do independently along with some activities that require the help of a fluent reader. Activities will vary from week to week, but each packet will include a combination of activities described below.

### **Most Common Words Cards**

Most Common Words are words that appear so frequently in writing that students should know them by sight. Simply have the student read the words aloud to help them practice rapid recognition skills.

### **Transfer Cards and Whole Class Transfer Cards**

These cards are designed to help students practice a particular reading skill that they've learned. They can be used a variety of ways. Consider the following ideas:

- Point to each word (in order or randomly) and have the student read it.
- Read the word aloud and have the student write the word on a piece of paper.
- Have the student illustrate the sentences on the cards.

### ***Reading Horizons Discovery*<sup>®</sup> Kindergarten Little Books**

Each skill lesson contains an accompanying Little Book showcasing words that include skills learned in the lesson. Encourage the student to read the book aloud to you. Then, read each comprehension question and allow the student to point to the correct response.

### **Practice Pages**

Instructions at the top may need to be read to the student.

### **Sort and Spell Activities**

In the Sort and Spell activities, the words can be cut out and moved into the appropriate columns on the sort page. The student could also use the words in the bank as a reference and write the words into the correct columns.

### **Cloze Passages**

The student should use the words on the second page of the activity to fill in the blanks on the first page. The passages are designed to include only words that the student has learned the necessary skills to read independently.

### **Writing Prompts**

Designed to help students write using skills they've learned, writing prompts may need to be read to the student by a fluent reader.

### **Building Words Activities**

The student should cut out the accompanying letter cards. A fluent reader should read the Building Words Activity script aloud to the student while the student uses the cards to spell the words. In some cases, it may be smart to break this activity up into two sessions to avoid overloading the student. The Building Words Transfer Card uses words from the Building Words Activity in sentences designed to help students practice reading skills.

### **Games**

Engaging games such as Bear It and the Blends Game are great tools for helping students practice their skills in a fun way. When games are included, you'll find the instructions along with all the necessary components to play. Consider storing the game components (such as Blends cards) for future use.

Happy Reading and Spelling!

The Reading Horizons Team

There are more than enough activities in each packet to keep a child engaged. You may find that the teacher will assign only certain pages each week. She or he may also send these packets home for a two week period. Be sure to follow whatever instructions are communicated by the teacher.

For more information, contact your teacher at \_\_\_\_\_.

# Letter Formation Consonant Z

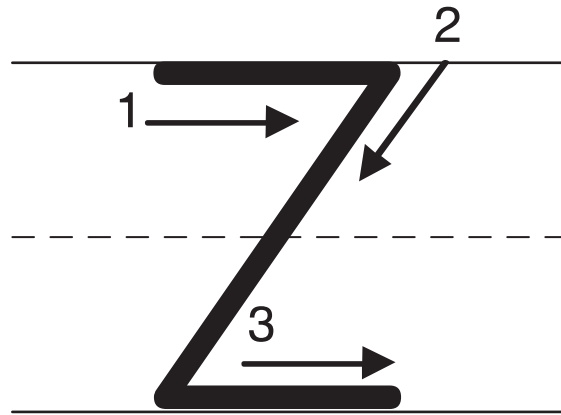

Copyright © April 2017

Reading Horizons Discovery® Kindergarten

# Letter Formation Consonant z

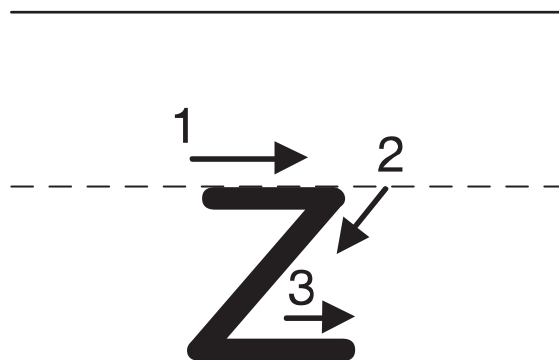

Published by Reading Horizons®

ISBN 978-1-62382-121-0

Name \_\_\_\_\_

The name of this letter is z. Z is a consonant. The sound of z is /z/, as in zip.

### Lesson 34: Consonant Z

Write rows of the letter z matching the example at the beginning of each row. Each time you write a letter, say the name and the sound: z, /z/; z, /z/.

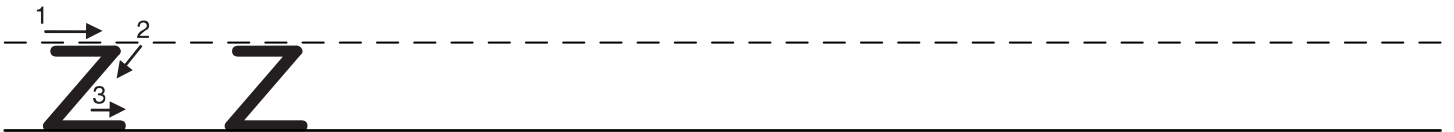
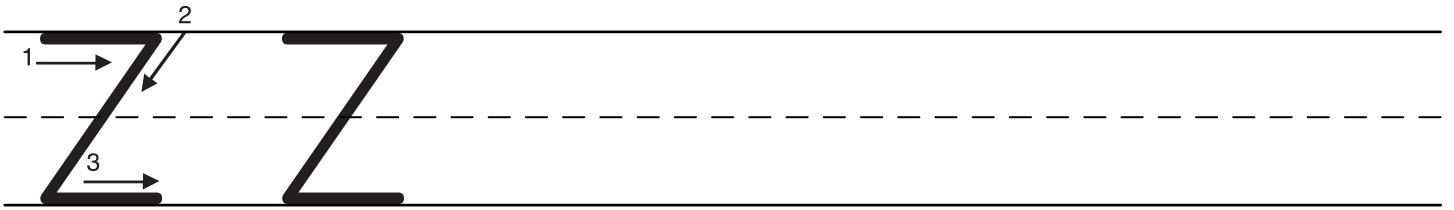

Write each slide with the slide arrow. Read each slide, and then write each word one time. Mark an x under the vowel. Then read the word.

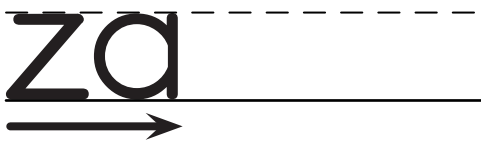
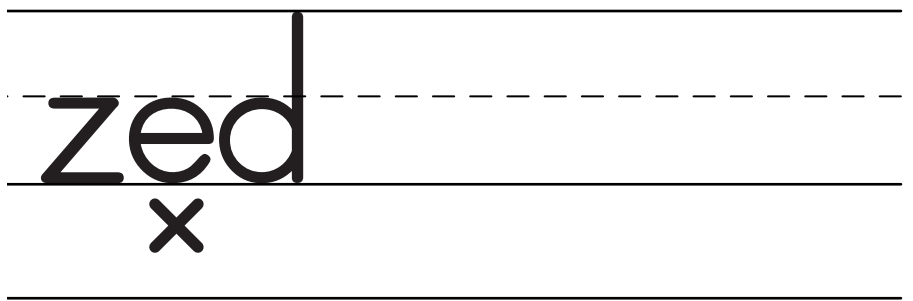
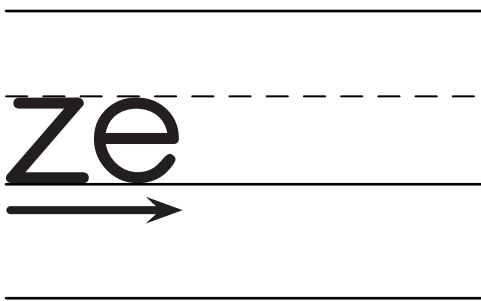

# Lesson 34: Consonant Z z

Name (Uppercase and lowercase):

Z z

Sound (/z/):

/z/ /z/ /z/

Name and Sound:

Z, /z/ z, /z/ z, /z/

Slides (/zǎ/ /zě/ /zö/ /zű/):

zǎ → ze → zo → zu →

Words:

\*zog \*zem \*zop \*zub

## Grab Bag

Objective: Letter/Sound recognition.

Materials: A bag and Alphabet Cards. (You will find the masters for these cards online at [www.rhaccelerate.com](http://www.rhaccelerate.com).)

To play: Select letters being studied from the Alphabet Cards, and put them in a bag. Have students pull out a letter and tell you its name and sound. This game can be played with the whole class, in small groups, or with partners.

<b>A</b>	<b>a</b>	<b>B</b>	<b>b</b>	<b>D</b>	<b>d</b>
<b>E</b>	<b>e</b>	<b>F</b>	<b>f</b>	<b>G</b>	<b>g</b>
<b>H</b>	<b>h</b>	<b>J</b>	<b>j</b>	<b>L</b>	<b>l</b>
<b>M</b>	<b>m</b>	<b>N</b>	<b>n</b>	<b>O</b>	<b>o</b>
<b>P</b>	<b>p</b>	<b>Q</b>	<b>q</b>	<b>R</b>	<b>r</b>
<b>S</b>	<b>s</b>	<b>T</b>	<b>t</b>	<b>U</b>	<b>u</b>
<b>V</b>	<b>v</b>	<b>W</b>	<b>w</b>	<b>X</b>	<b>x</b>
<b>Y</b>	<b>y</b>	<b>Z</b>	<b>z</b>		

